

SC360.8 (LC)

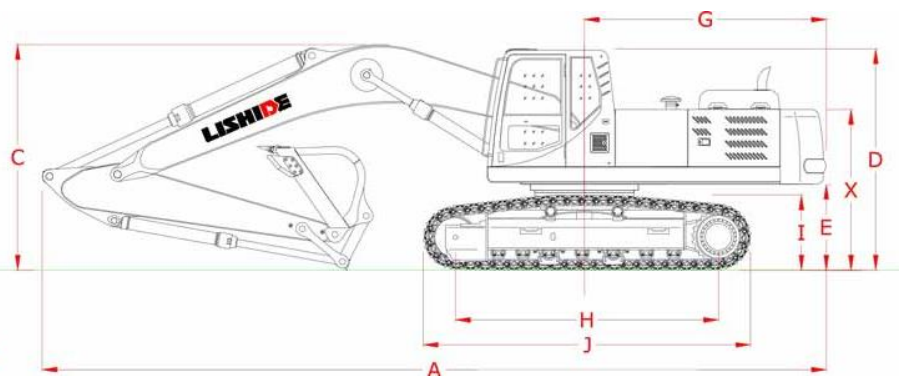
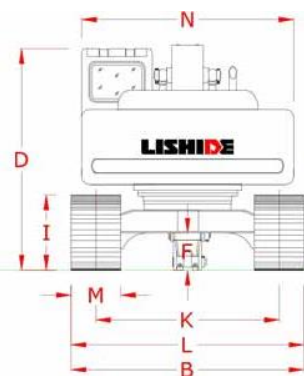
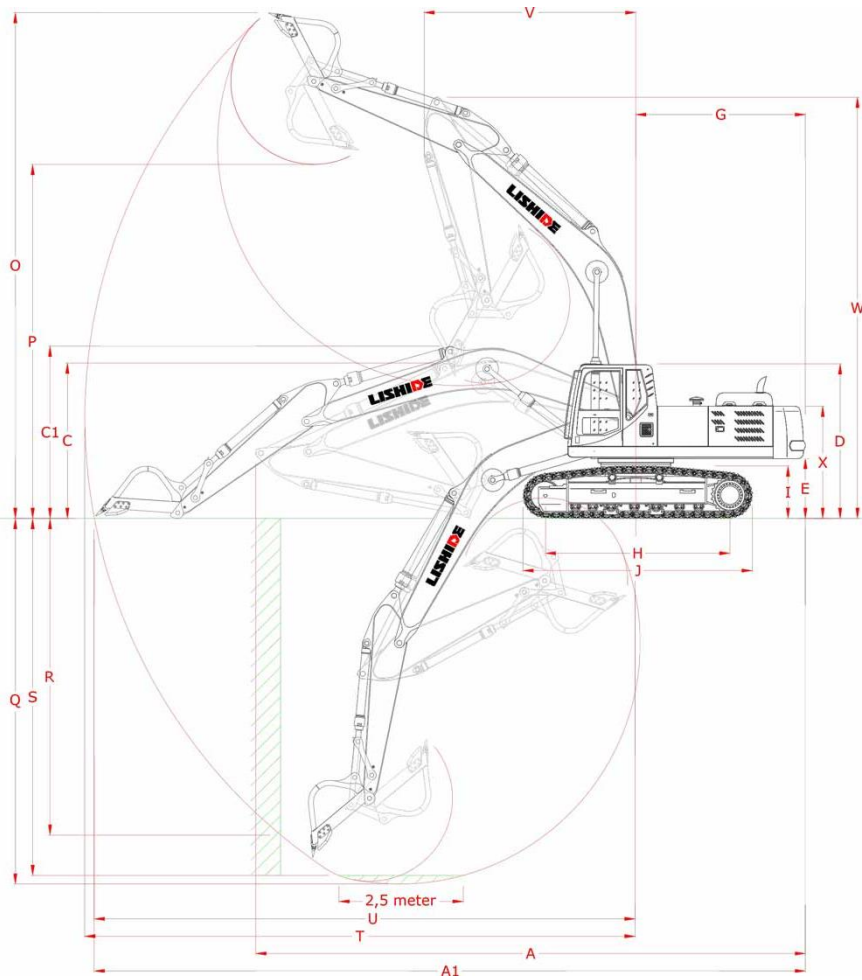

| Model | | SC360.8 | SC360.8LC |
|---|-------------------|------------|------------|
| Operating weight (Machine equipped with track shoe width 700 mm) | (kg) | 34485 | 34910 |
| Ground pressure (Machine equipped with track shoe width 700 mm) | (kPa) | 60,2 | 55,9 |
| Bucket capacity | (m ³) | 1,6 | 1,6 |
| Engine power | (kW/h) | 198 | 198 |
| Rated speed | (rpm) | 2000 | 2000 |
| Volume of fuel tank | (L) | 595 | 595 |
| Maximum travel speed | (km/h) | 5.2 / 3.3 | 5.2 / 3.3 |
| Rotating speed | (r/min) | 10,6 | 10,6 |
| Maximum gradeability | (%) | 70 | 70 |
| Bucket digging force | (kN) | 208 | 208 |
| Hydraulic pump model | | K3V140DT | K3V140DT |
| Maximum flow | (L/min) | 265*2 | 265*2 |
| Working pressure | (mPa) | 34,3 | 34,3 |
| Volume of hydraulic tank | (L) | 310 | 310 |
| Number of track pads | | 2*50 | 2*53 |
| Number of upper rollers | | 2*2 | 2*2 |
| Number of bottom rollers | | 2*7 | 2*8 |
| Arm length | (mm) | 3185 | 3185 |
| Boom length | (mm) | 6470 | 6470 |
| A : Overall length (With arm in short position) | (mm) | 11260 | 11260 |
| A1 : Overall length (With arm in stretched position) | (mm) | 14330 | 14330 |
| B : Overall width (Track shoe width 700 mm.) | (mm) | 3290 | 3290 |
| C : Overall height (To top of boom with arm in short position) | (mm) | 3180 | 3180 |
| C1 : Overall height (To top of boom with arm in stretched position) | (mm) | 3475 | 3475 |
| D : Overall height (To top of cabin) | (mm) | 3280 | 3280 |
| E : Counterweight ground clearance | (mm) | 1210 | 1210 |
| F : Minimum ground clearance | (mm) | 520 | 520 |
| G : Tail swing radius | (mm) | 3600 | 3600 |
| H : Track length on the ground | (mm) | 3700 | 4030 |
| I : Track height | (mm) | 1060 | 1060 |
| J : Track Length | (mm) | 4625 | 4955 |
| K : Track gauge | (mm) | 2590 | 2590 |
| L : Total track width (Track shoe width 700 mm.) | (mm) | 3290 | 3290 |
| M : Track shoe width | (mm) | 700 | 700 |
| M : Other track shoe width are available. | (mm) | On request | On request |
| N : Width of upper structure | (mm) | 2995 | 2995 |
| O : Maximum digging height | (mm) | 10200 | 10200 |
| P : Maximum dumping height | (mm) | 7135 | 7135 |
| Q : Maximum digging depth | (mm) | 7370 | 7370 |
| R : Maximum digging depth right next to a vertical wall | (mm) | 6380 | 6380 |
| S : Maximum digging depth with a 2,5 meter wide horizontal level | (mm) | 7190 | 7190 |
| T : Maximum digging distance | (mm) | 11100 | 11100 |
| U : Maximum digging distance on ground level | (mm) | 10900 | 10900 |
| V : Minimum swing radius | (mm) | 4265 | 4265 |
| W : Overall height (of the minimum swing radius) | (mm) | 8490 | 8490 |
| X : Overall height (to top of counterweight / backside) | (mm) | 2265 | 2265 |

| Model SC360.8 and SC360.8LC Machine equipment | Standard | Optional |
|--|-----------------|-----------------|
| Adjustable air suspension seat with wrist rests and safety belt | ✓ | |
| Clothes hook | ✓ | |
| Floor mat | ✓ | |
| Coolbox | ✓ | |
| Coffee cup / bottle holder | ✓ | |
| Rearview mirrors | ✓ | |
| Rearview camera(s) | | ✓ |
| Shock absorbers for the cabin | ✓ | |
| Falling objects protection for the cabin | | ✓ |
| Roll-over protection | | ✓ |
| Airconditioning and heating | ✓ | |
| Radio with usb connection point | ✓ | |
| GPS (machine monitoring / theft prevention) | | ✓ |
| window protecting covers (vandalism / theft prevention) | | ✓ |
| Electronic theft prevention system | | ✓ |
| Pin number start interrupter | ✓ | |
| Internal / external tool box | ✓ | |
| Lockable machine covers | ✓ | |
| Window wiper and sprinkler | ✓ | |
| Klaxon | ✓ | |
| Maintenance free battery | ✓ | |
| Side boards on the upper structure of the machine (left/right) | | ✓ |
| Multiple language settings / English text on instruments / machine parts | ✓ | |
| Documents storage compartment | ✓ | |
| Safety hammer | ✓ | |
| Fire extinguisher | ✓ | |
| Warning light(s) / Rotating light(s) | | ✓ |
| Working lights | ✓ | |
| Interior light | ✓ | |
| Steel tracks | ✓ | |
| Rubber tracks | | ✓ |
| Steel tracks with rubber pads | | ✓ |
| Different track width | | ✓ |
| Track guard full length of undercarriage | | ✓ |
| Hose breakage protection / non return valves | ✓ | |
| Adjustable flow control for additional equipment | ✓ | |
| Protection cover(s) for cylinders | | ✓ |
| Additional hydraulic connection with quick coupling | | ✓ |
| Hydraulic oil cooler | ✓ | |
| Automatic lubrication system | | ✓ |
| Hydraulic quick coupler for easy change of buckets / attachments | | ✓ |
| Different types boom and arm (different lengths) | | ✓ |
| Different type of buckets / attachments | | ✓ |
| Machine finishing, color according to customer specifications | | ✓ |
| Special customer requirements are negotiable. | | |